



The New Westwind Air Bearings Speed Probe Sensor

Published: By Steve Warner, Westwind Air Bearings, 8 November 2004

Technical Support, Westwind Air Bearings

Holton Road, Holton Heath, Poole, Dorset. BH16 6LN. United Kingdom.

Tel: +44 (0) 1202 627200 Fax: +44 (0) 1202 627208 Email: support@westwind-airbearings.com



The New Westwind Air Bearings Speed Probe Sensor

Brief Description

Due to the obsolescence of the Infineon FP212L100 speed sensor, Westwind Air Bearings has been pro-active in testing alternative speed sensing devices and, after rigorous evaluations, has found a proven alternative. Westwind has worked closely with Sieb & Meyer throughout the testing and evaluation period to ensure a seamless change over from the historically used sensor.

Both the old and new devices are an Analogue sinusoidal differential magnetic biased sensor coupled with an amplifier circuit that switches in response with moving ferrous target (e.g. cut outs in the spindle shaft) with operation frequencies in excess of the existing device.

The speed sensor assembly has been designed to fit within the dimension envelope of the old device to prevent any backwards compatibility problems.

Please note: The new sensor has a built-in amplifier; therefore it is no longer viable to test the sensor as a stand-alone device by measuring the resistance between wires alone. A 5 volts supply is required and the output signal to be measured when a target passes across the sensor face. Westwind recommends this be carried out with the sensor fitted within the spindle and using the SCE020 speed sensor test box. This unit can be used in conjunction with the Westwind test set or with a 5-volt supply; the resultant signal can be measured with a suitable oscilloscope or via the test set (see test box set-up details).

Warning: This device has no inbuilt reverse polarity protection, therefore it is essential that the correct wiring be adhered to as per the outline drawing of the spindle.



The New Westwind Air Bearings
Speed Probe Sensor

Specification

Input Voltage	5 V single supply operation less than 20mV ripple +/- 100mV range
	Rail to rail input common mode voltage range
Output voltage	600 to 800 mV peak to peak
Driving load capability	250 ohm
Typical max supply current	1.1A (dependant on load resistance)
Offset voltage	2.5V

Block Diagram

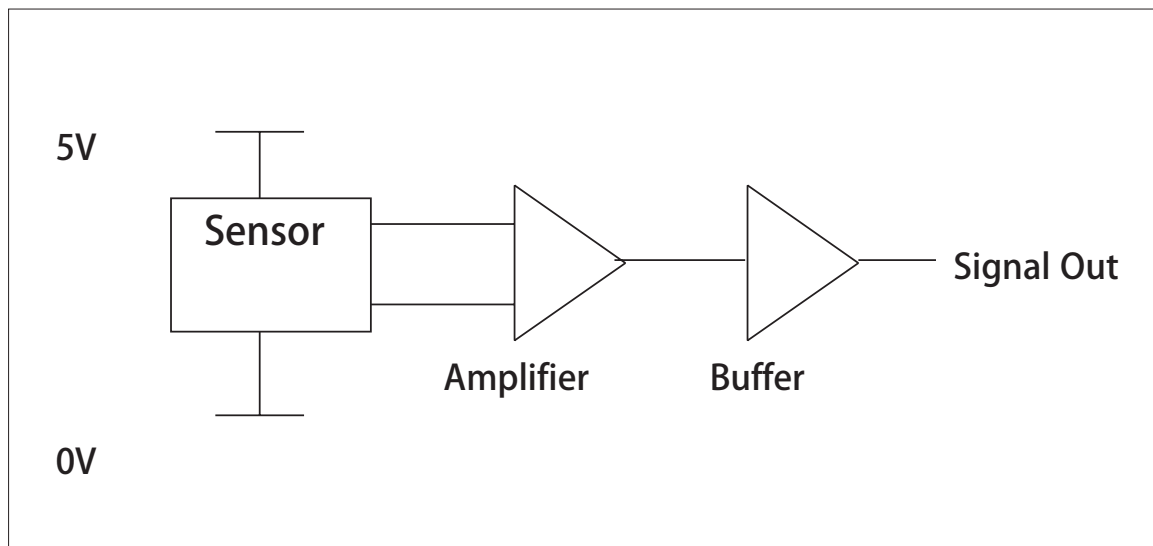



The New Westwind Air Bearings
Speed Probe Sensor

Test box set-up

Block Diagram

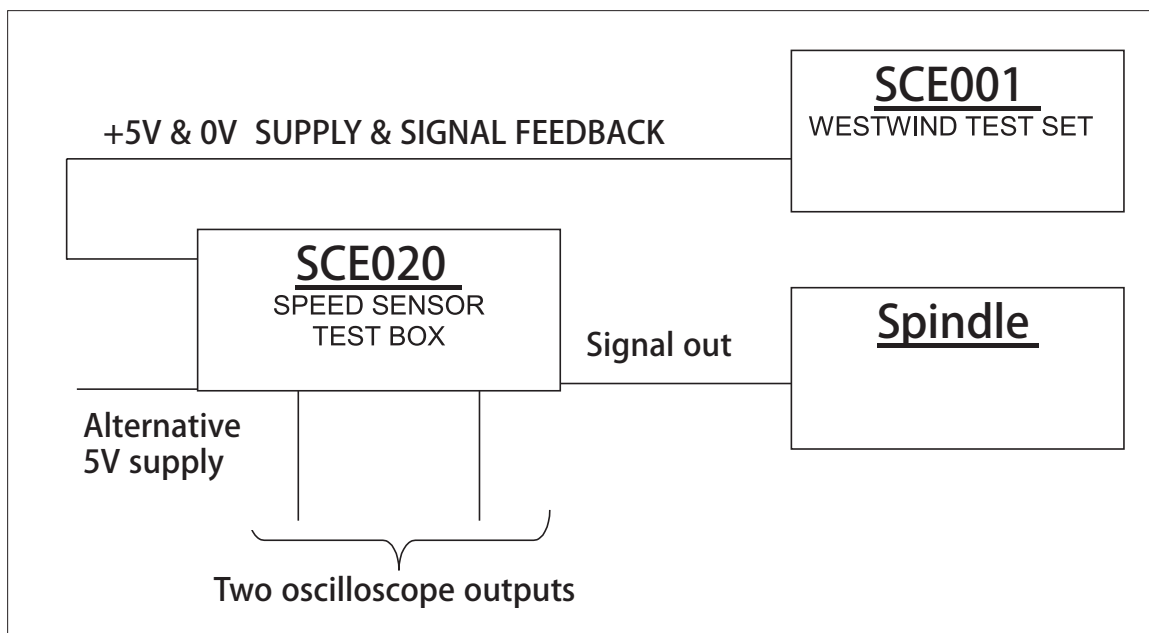

Description

The SCE020 has been designed for easy testing of the new speed sensor with the minimum requirement for any other test equipment interfacing with the existing Westwind test set. The SCE020 has also been designed to ensure the signal output is fully compatible with the Sieb & Meyer drive units.

The option of operating and testing the speed sensor without the need for a Westwind test set has been included. For this operation, a 5v supply is required with less than 20Mv ripple +/- 100Mv range and a two-channel oscilloscope 20MHz. The two oscilloscope outputs' provide the ability to monitor the analogue sensor waveform and view a simulation of the Sieb & Meyer drive interface digital signal.